

# Halogen free Flame Retardant (HFFR.LS0H, LSF)

*Halogen-Free, Flame Retardant Compounds*



# Selected topics: **HFFR cables**

- **Cable installation**
  - **Danger in case of fire**
  - **Definition of HFFR**
- 
- **Over view about fillers and reaction in case of fire**
  - **Material testing and Standards for HFFR cables**
- 
- **Extruder equipment**
  - **Processing parameters**
  - **Cable construction – bending test**
  - **Crosslinkable HFFR**

# HFFR: Introduction

Cables are often installed as bunch in cable funnels

In case of fire – Danger for fire expansion to next floor's

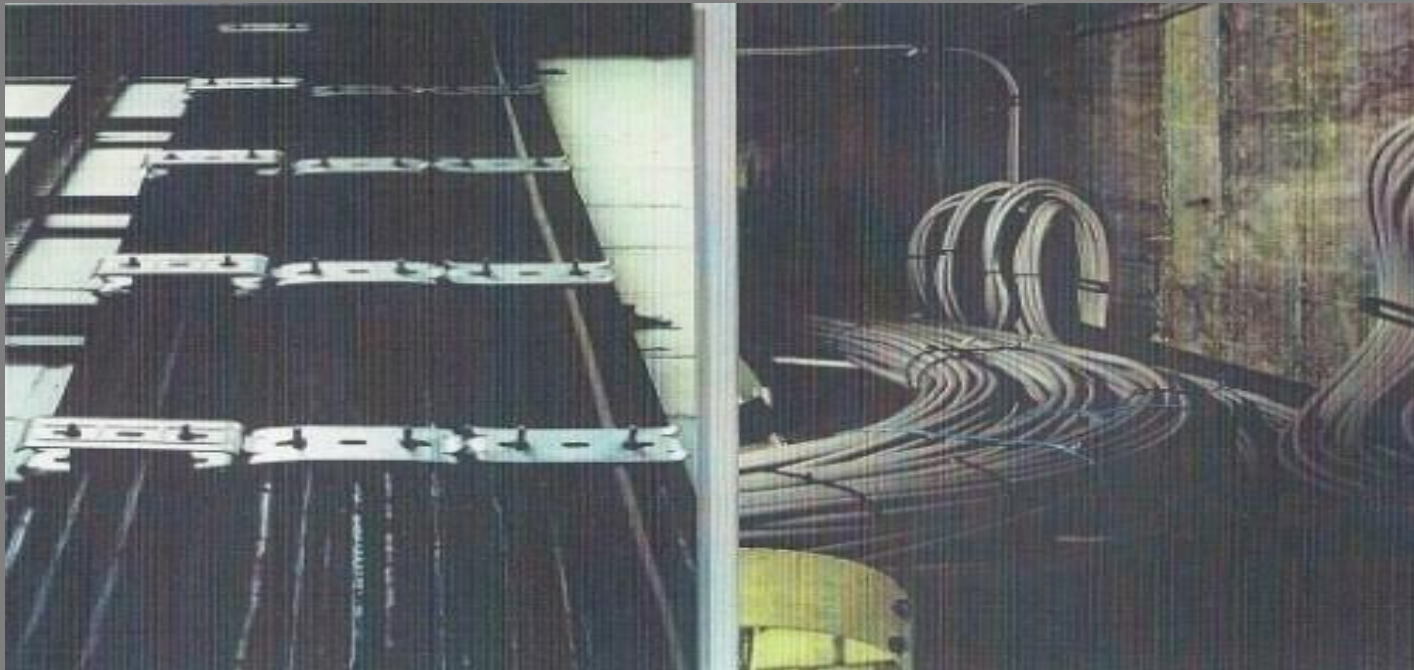

**More than 80 % of Fire Death are caused by Smoke and Toxic gases, only 20 % got burned**



# Comparison: Jacketing material

## PE medium and high density (PE-MD; PE-HD)

- Excellent environment stress cracking
- hard surface – high mechanical strength - low abrasion
- good barrier properties
- excellent UV stability with carbon black
- environmental friendly

## PVC

- Good processibility
- Flexible cable laying
- Flame retardant; but in case of fire corrosive and toxic gases

## HFFR-Compounds

- Halogenfree, flame retardant material
- Improvement of fire resistants with mineral filler like
- Aluminiumhydroxid - Magnesium
- Calk, silicon

# HFFR: Danger in case of cable fire

**PCV Insulated cables and most fluoropolymers give up**

- 1. High density of black smoke**
- 2. Toxic and corrosive fumes like hydrochloric acid gas**

**Inhalation of smoke like carbon monoxide and carbon dioxide results in deaths of people within minutes**

- Because of high smoke People can't find the way to go out**
- Fire brigade can't see the flames**
- Inhalation of toxic and corrosive emission gives irreversible damages of health**
- Corrosive emission like hydrochloric acid is dangerous for all electrical / electronic and metallic equipment inside Buildings**
- High heat release of flame energy (unfilled polyolefins)**

# HFFR : Introduction

## Two main flame retardant categories:

1. Halogenated polymers are flame retardant due to their chemical structure

- PVC compounds
- chlorparaffin
- brominated FR
- Fluor thermoplast & elastomers

2. Halogen-free polymers needs additives to pass flame tests

- Polyolefin / chalk / (silicon)
- Polyolefin / metal hydroxide  $\text{Al}(\text{OH})_3$  /  $\text{Mg}(\text{OH})_2$  / Silicate
- Silicon rubber

# Material characteristics

## Carbon monoxide formation

## Acidity of combustion fumes

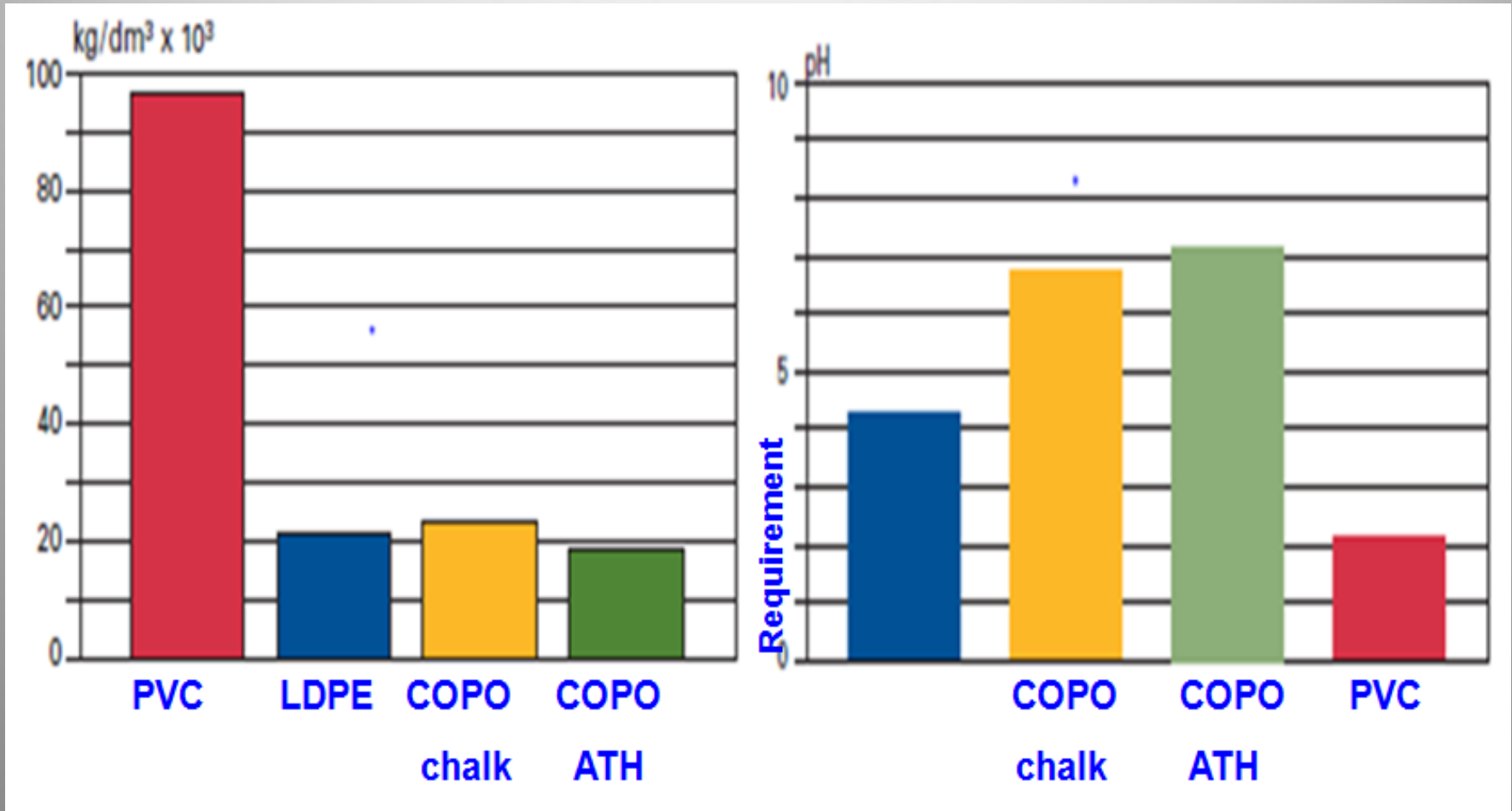

# HFFR : Definition

HFFR = Halogen Free Flame (or Fire) Retardant (or Resistant)

other terms:

LSOH = Low Smoke Zero Halogen

FRNC = Flame (or Fire) Retardant Non-Corrosive

Zero Halogen means:



No Chlorine

No Bromide

No Fluorine

No Iodine

# HFFR : Introduction

## Requirements on HFFR cables

- High flame retardancy
- Low toxicity of smoke emission
- No halogen / no corrosive gases
- Low calorific load

## HFFR cables are mainly used for

- Buildings, like hospitals, airports, schools, commercial centers
- Public transportation, like subway, railways, airplanes
- Computer rooms, telephone centers
- Industrial areas, like power plants

# Selected topics: **HFFR cables**

## **Summary:**

- Cable installation
- Danger in case of fire
- Definition of HFFR

## **Next:**

- **Over view about fillers and reaction in case of fire**
- **Material testing and Standards for HFFR cables**

# HFFR : Inorganic additives (Fillers)

	Flame protection system	Advantage 😊	Disadvantage
Flame retardant	Chalk / silicon	Low content of filler Low cost system Easy processing	Limited fire retardancy
Fire retardant	Aluminium Trihydrate (+ chalk)	Standard system High fire retardancy	High content of filler Special extruder design
	Magnesium hydroxide	High fire retardancy Simulate to ATH Higher melt temperature	High content of filler Higher cost compare to ATH
	Special additives Nanofiller Silicate	Additive to all systems Lower heat release Ash stability	Cost increase

## Filler: **Metal hydroxides are**

- Halogen-free
- Environmentally friendly
- Non-toxic
- Not volatile
- Substantial reduction of smoke
- No corrosive or toxic decomposition products
- Reduction of subsequent damages

## Filler: **ALUMINIUM HYDROXIDE**

On heating to 200°C, hydrated alumina decomposes into 66% alumina oxide and 34% water.



A cable contains about 70% by weight of  $\text{Al(OH)}_3$  therefore a HFFR cables has about 25% of water, which is about the amount of polymer in the cable.

# HFFR – Function of metal hydroxides

- Dilution of the Polymer
- Cooling due endothermic reaction of filler
- H<sub>2</sub>O vapour reduces Oxygen concentration and burnable gases
- Formation of barrier layer (**ash**)

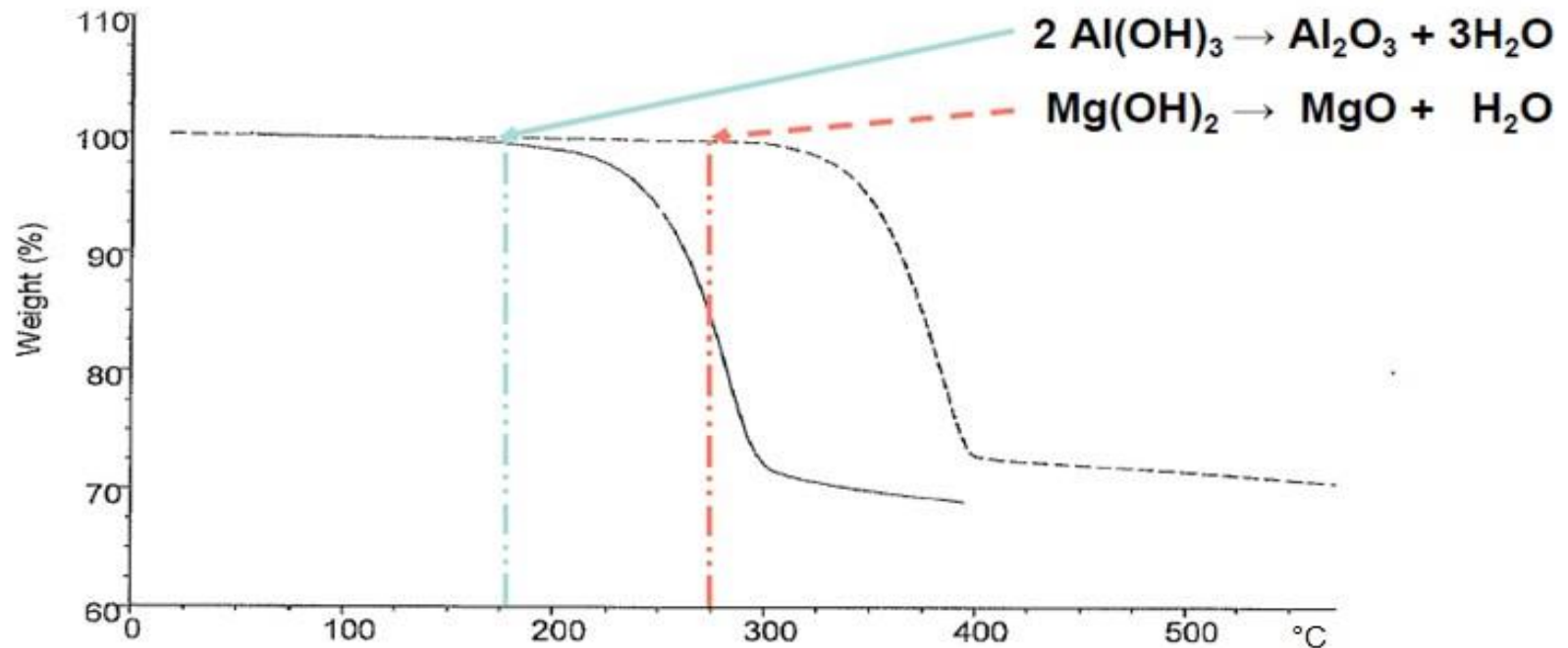

# Flame Retardancy during burning

- a) Endothermic reaction → total heat consumption of these reaction reduce the temperature of the flame



- b) The released water vapour cools the surface of the polymer and particularly dilutes the concentration of burnable gases in the surrounding area
- c) The remaining metal oxide residue has a high internal surface where sooty particles, EG polycyclic aromatic hydrocarbons, are adsorbed thus reducing the amount of flammable material
- d) The oxide residue becomes a skin which acts as a material barrier, disabling the further release of low molecular weight (easy to burn) decomposition products and acts as a heat barrier protecting the polymer against further decomposition
- e) Protective cloud of CO<sub>2</sub> and steam prevents air (oxygen) from reaching the fire
- f) Charred material keeps the insulation intact during the fire

# MECHANISM FOR HEAT RETARDANCY

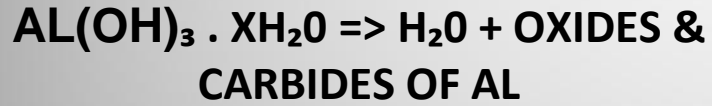

Endothermic reaction of filler  
Reduce Temperature of Flame

Cloud Prevents oxygen from entering

SKIN: acts as a barrier for air to propagate the flame

CO<sub>2</sub> + H<sub>2</sub>O LAYER

Metal oxides adsorb combustible material

CHAR: keeps the insulation intact  
Cable still working

CONDUCTOR

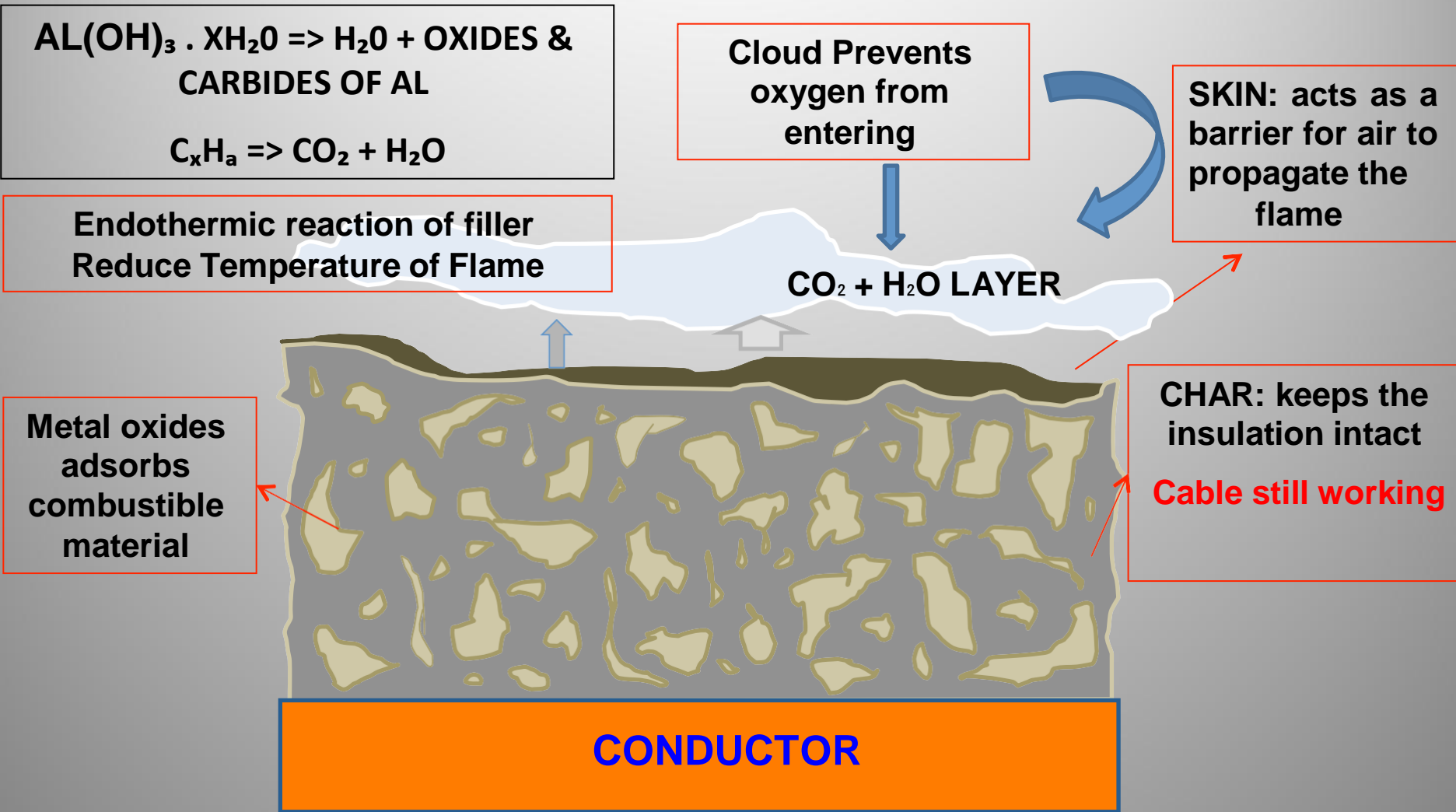

# **HFFR: COPO based - CHALK filled**

- **LOW OXYGEN INDEX – CLOSE TO THAT OF STANDARD PVC - Compound (LOI = 26-30)**
- **LOW COST COMPOUND TO COMPETE WITH PVC**

# MECHANISM FOR CHALK RETARDANCY

Reaction during thermal treatment of COPO in present of chalk

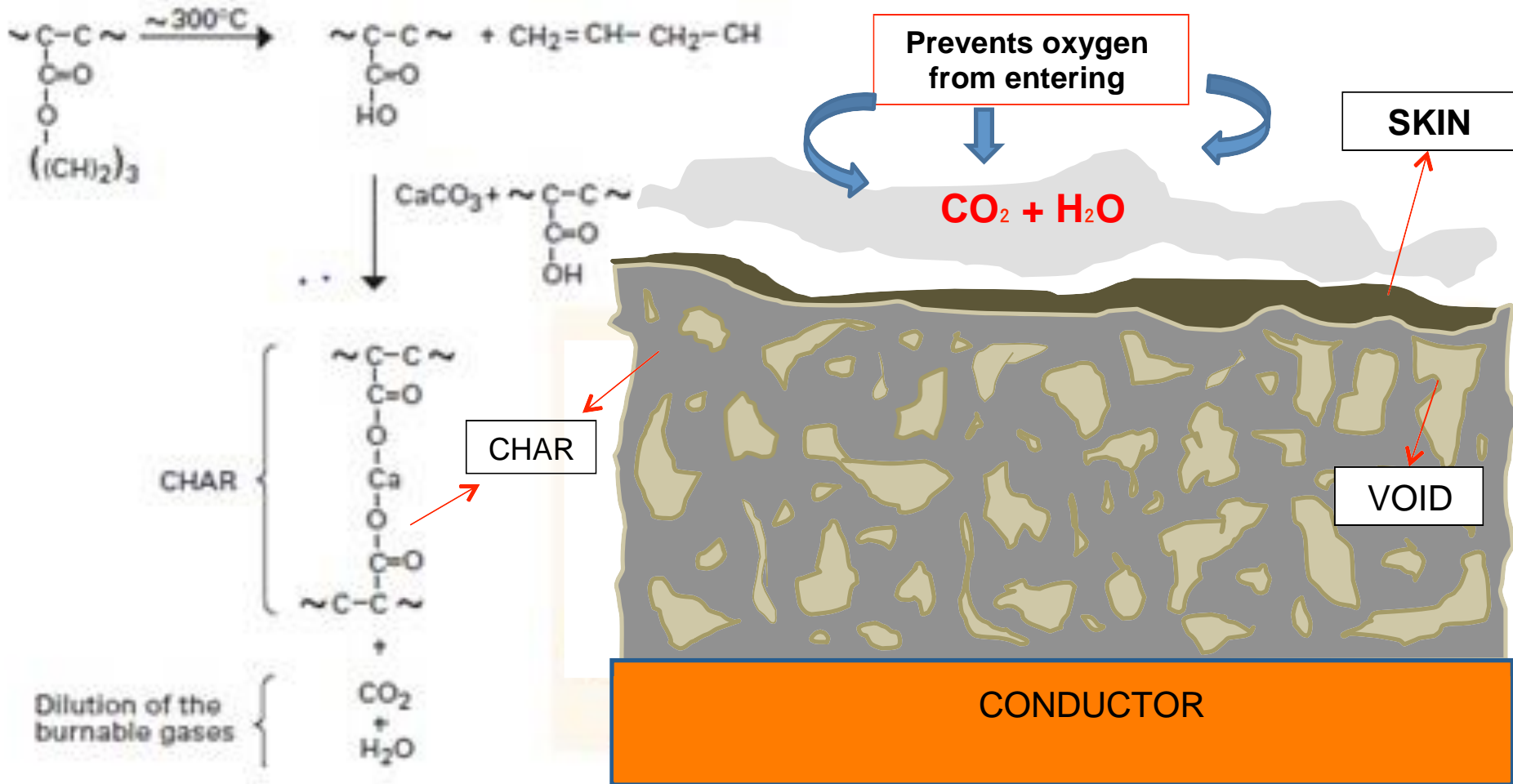

# Material test : Oxygen index (LOI)

Minimum Concentration of oxygen that will support combustion of polymer



Typical Results:	LOI %
LDPE / XLPE	18
PVC	26-33
COPO/SI/Chalk	26-33
COPO/Al(OH) <sub>3</sub>	30-40



**Limited Oxygen Index  
LOI (ASTM 2863A)  
TOI (ASTM 2863D)**

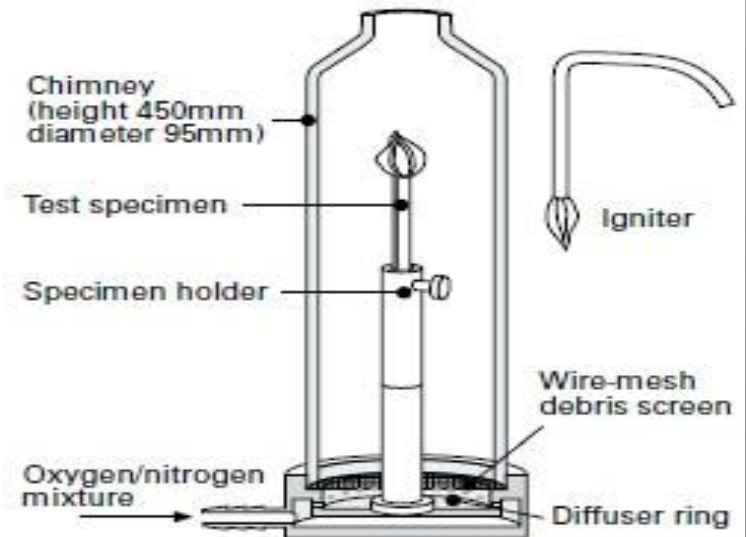

# Material test: Corrosivity of gases

## Standard IEC 60754

- Test conditions:
- 1 g of Material
- heat of 900 °C for 20 minutes

## Requirements:

- Acidity of emitted gases  $\text{pH} > 4,3$
- Conductivity  $< 10 \mu\text{S}$

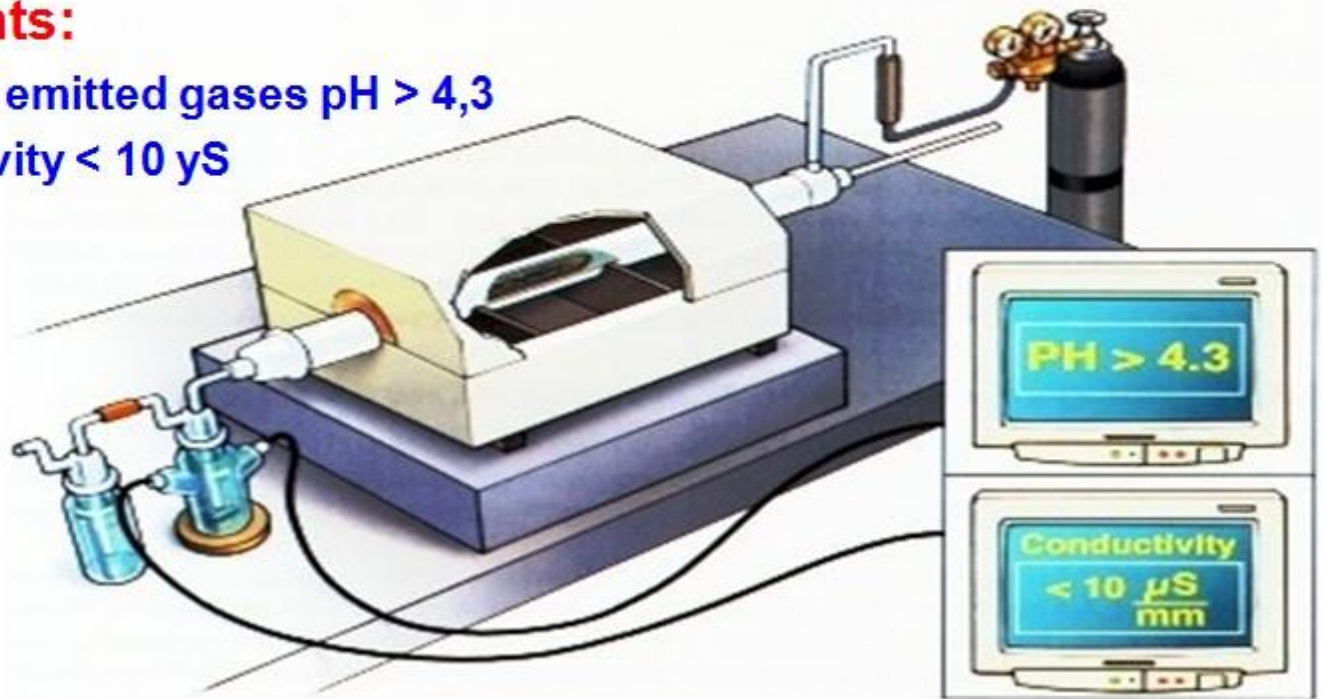

# Material test: Cone Calorimeter, ISO5660

## Principle of oxygen consumption calorimetry

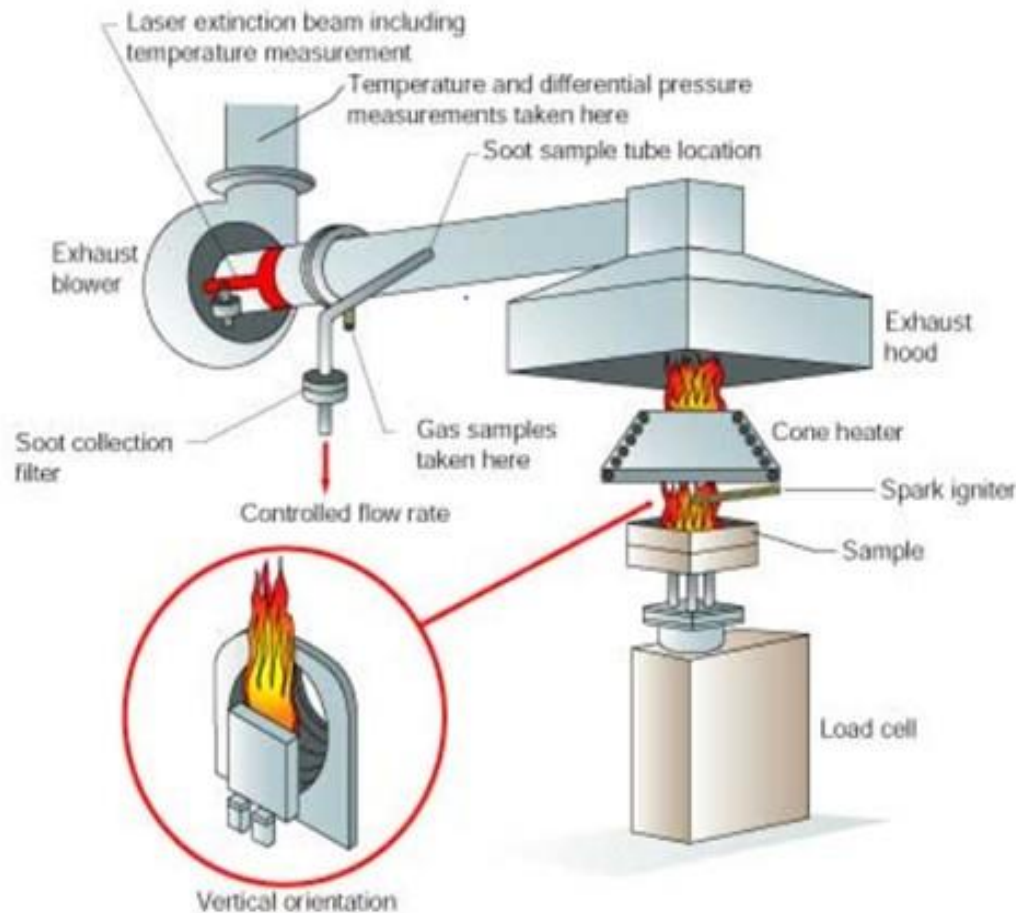

- Rate of smoke
- Rate of heat release
- CO and CO<sub>2</sub> concentration
- Ignition time
- Burning time
- Heat of combustion

# Material test: Rate of Smoke

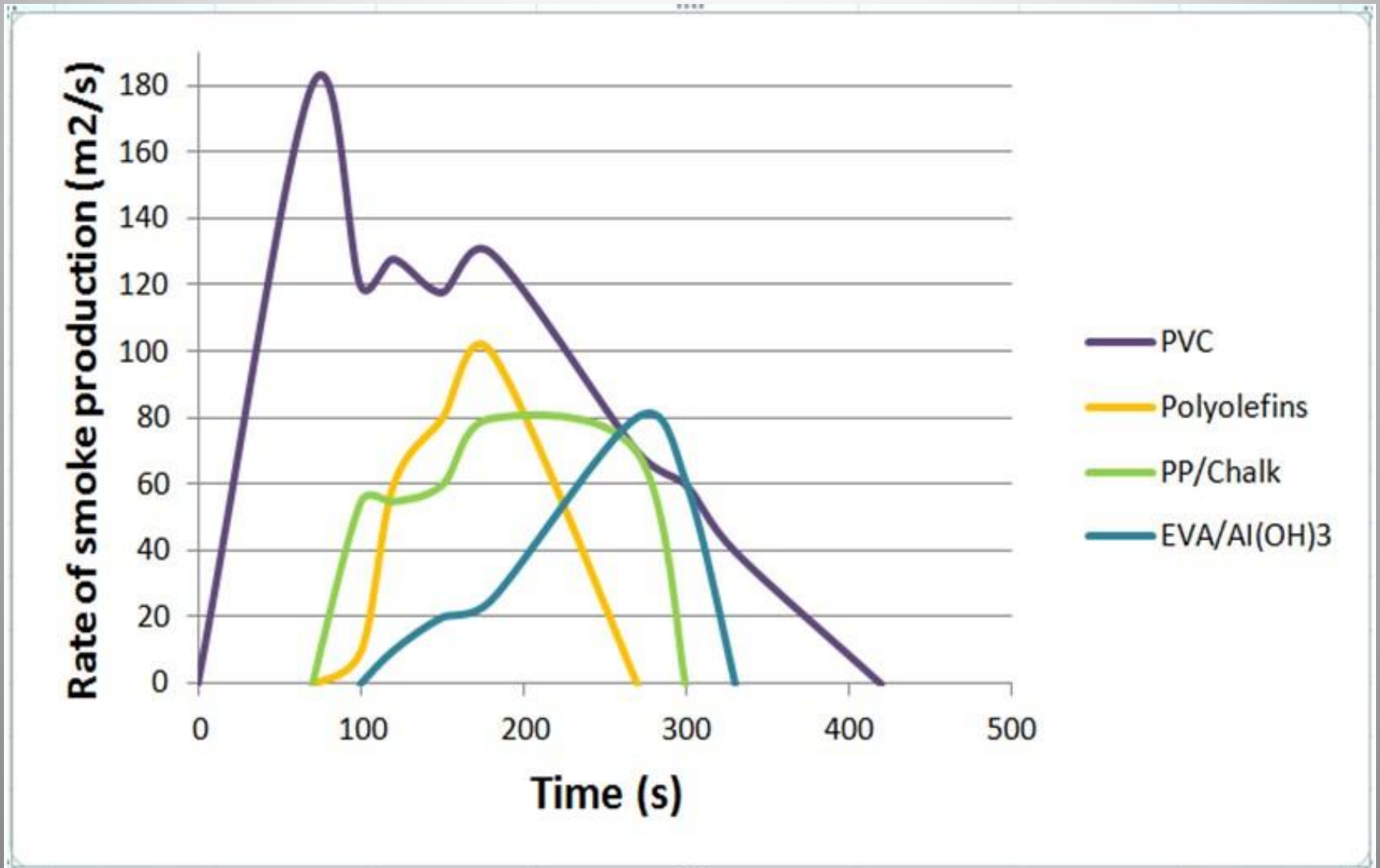

# Material test: Rate of Heat release

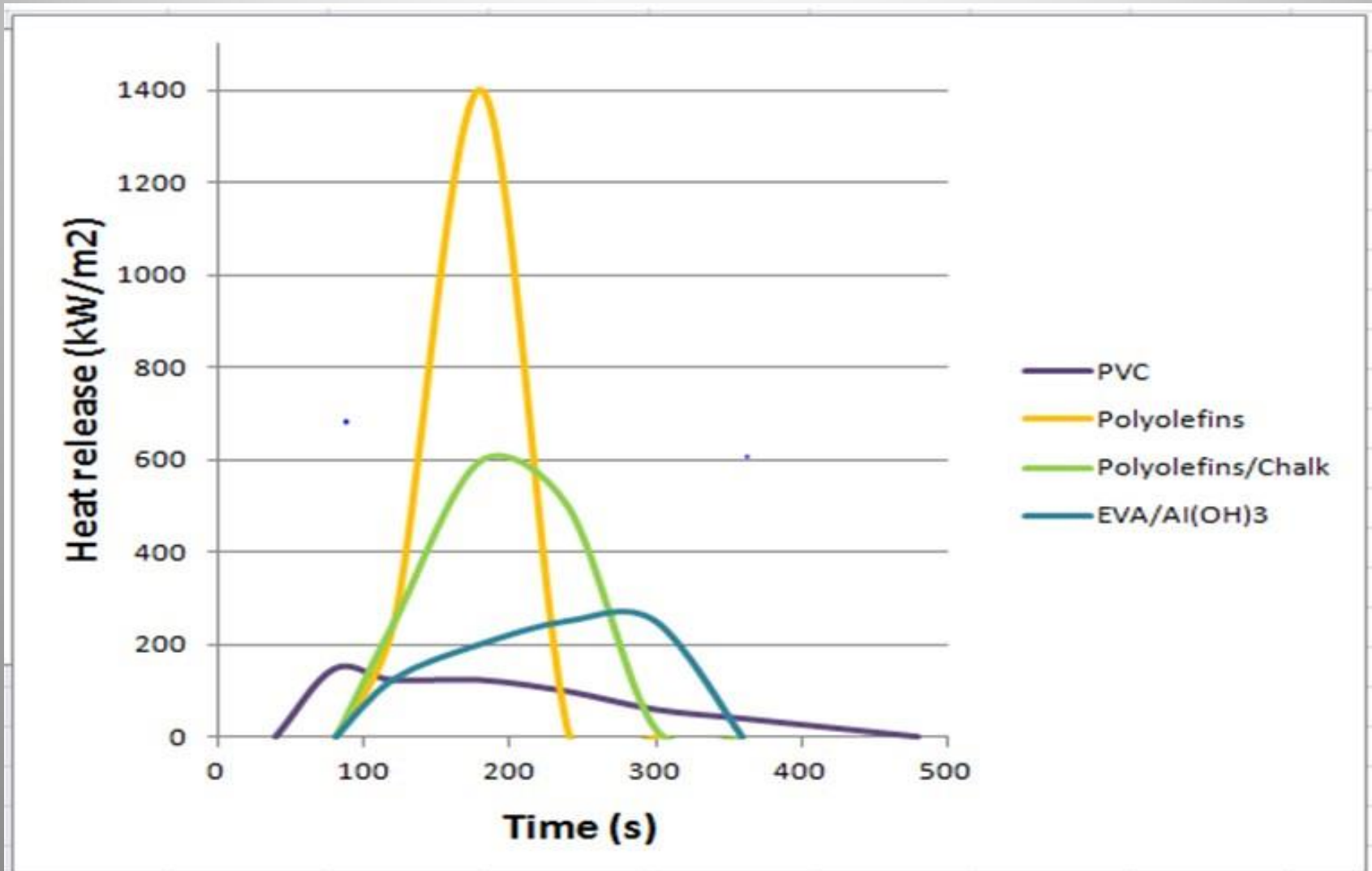

# Cable test: Measurement of smoke density

## Standard IEC 61034

### Test conditions:

- Cubic room 3x3x3 m, with glass window
- Source of light 2000 – 3000 lm
- Fire source 1000 cm<sup>3</sup> alcohol
- Cable sample 1 m long
- Number of samples depends on diameter
- Optical measurement of light transmission

### Requirement:

- Light transmission > 60%

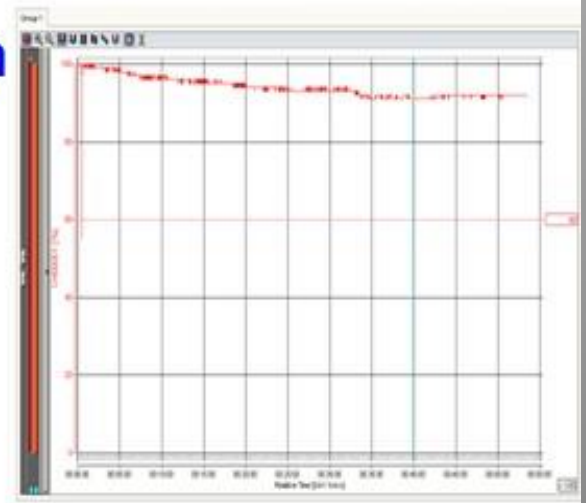
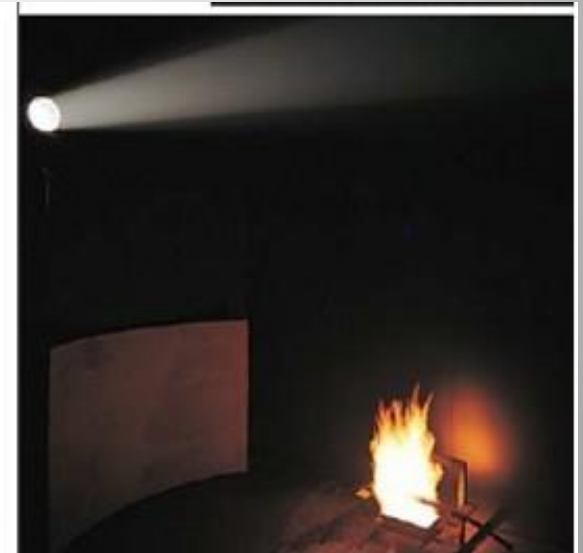

# Cable test: Flame test on single cable

## Standard IEC 60332-1

### Test conditions:

- single cable
- length of cable: 600 mm
- Flame: blue core (1200 °C)
- Flame: yellow (part 2)
- Flame time: depends on diameter

Diameter (mm)	Flame time (s)
$D \leq 25$	60
$25 < D \leq 50$	120
$50 < D \leq 75$	240
$D > 75$	480

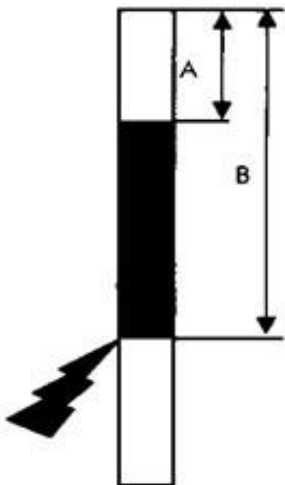

### Requirements:

- Fire self extinguishing
- Fire must stop between

$A \geq 50$  mm and  $B \leq 540$  mm



# Cable test: Flame test on bunched cables

## Standard IEC 60332-3

	Category A	Category B	Category C
Volume of non metallic material (l/m)	7	3,5	1,5
Flame time(min)	40	40	20

## Test conditions and requirements:

- Cable lengths 3,5 m
- Damaged lengths over burner  $\leq 2,5$  m



# Cable test: Flame test on bunched cables



# Cable test: Calculation of burnable material

## > Calculation of non metallic Elements for 1m of Cable

Length of sample cm: 30,0

Cable diameter mm: 33

Material		Weigh of material (g)	Desity (g/ml)	Volume (l/m)
Jacketing	HFFR	116,5	1,50	0,259
Bedding		-	-	-
Tape	HFFR tape	14,3	1	0,048
Tape	Paper	4,5	1	0,015
Insulation	XLPE	109,9	0,92	0,397
Volume for 1 m of Cable				0,717

## > Calculaton of Number of cable samples

Length of sample / latter 3,5 m

	Standard according IEC 60332-3, bunched cable		
Burnable material (l/m)	Category A	Category B	Category C
Number of sample			2
Number of laying			1
Used Cable (m)			7

# Definition of flame retardant / fire resistance

**What is the difference between Flame retardant and Fire resistance of cables ?**

- 1. Flame retardant cables resist the spread of fire into a new area**
- 2. Fire resistance cables must provide circuit integrity under specified conditions over 3 hours at 700 °C according the standard IEC 60331**

# HFFR : Fire resistance test IEC 60331

## Test conditions

- fire in undefined space
- single cable
- defined gas/air mixture
- flame temperature (min 750°C)
- inflammation 180 min
- test voltage is the nominal voltage of the cable

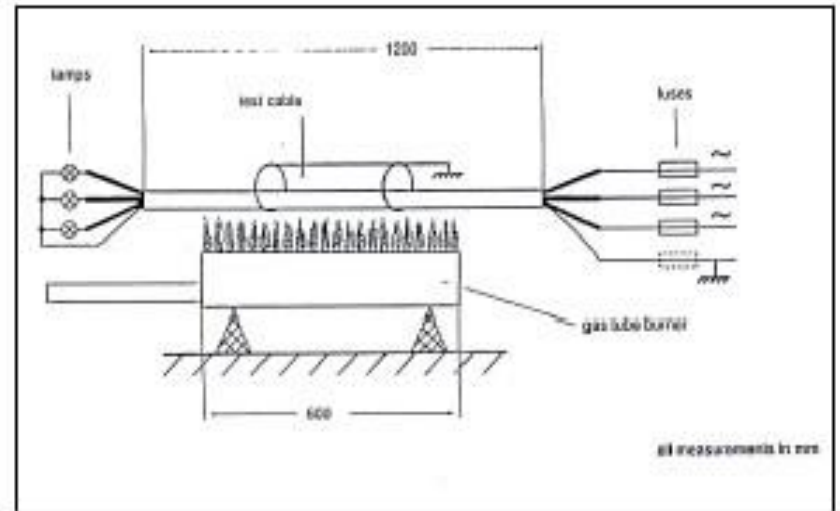

## Requirements

- no reaction of the corresponding fuses
- no interruption of the conductor

## Comparable tests

- NBN C 30-004

# Over view about Standards for HFFR material and cables

## Reaction to fire

flame retardant	IEC 60332-1, EN 50265	flame test on single cable
	IEC 60332-2, EN 50265	flame test on single cable
fire retardant	IEC 60332-3, EN 50266	fire on bunched cables

## Resistance to fire

fire resistant	IEC 60331, EN 50200 BS 6387	test to operational maintenance for certain period of time
----------------	--------------------------------	--

**Smoke density** EN 50268, IEC 61034 cube test, 27m<sup>3</sup> chamber

**Corrosivity** EN 50267  
IEC 60754 determination of halogens,  
acidity and conductivity

**Toxicity** NES 713  
EN 50305 determination of content of  
several specific gases

# HFFR - Selected topics for HFFR cables

## Summary:

- Cable installation
- Danger in case of fire
- Definition of HFFR
- Over view about fillers and reaction in case of fire
- Material testing and Standards for HFFR cables

## Next:

- **Extruder equipment**
- **Processing parameters**
- **Cable construction – bending test**
- **Crosslinkable HFFR**

# Units of extruder

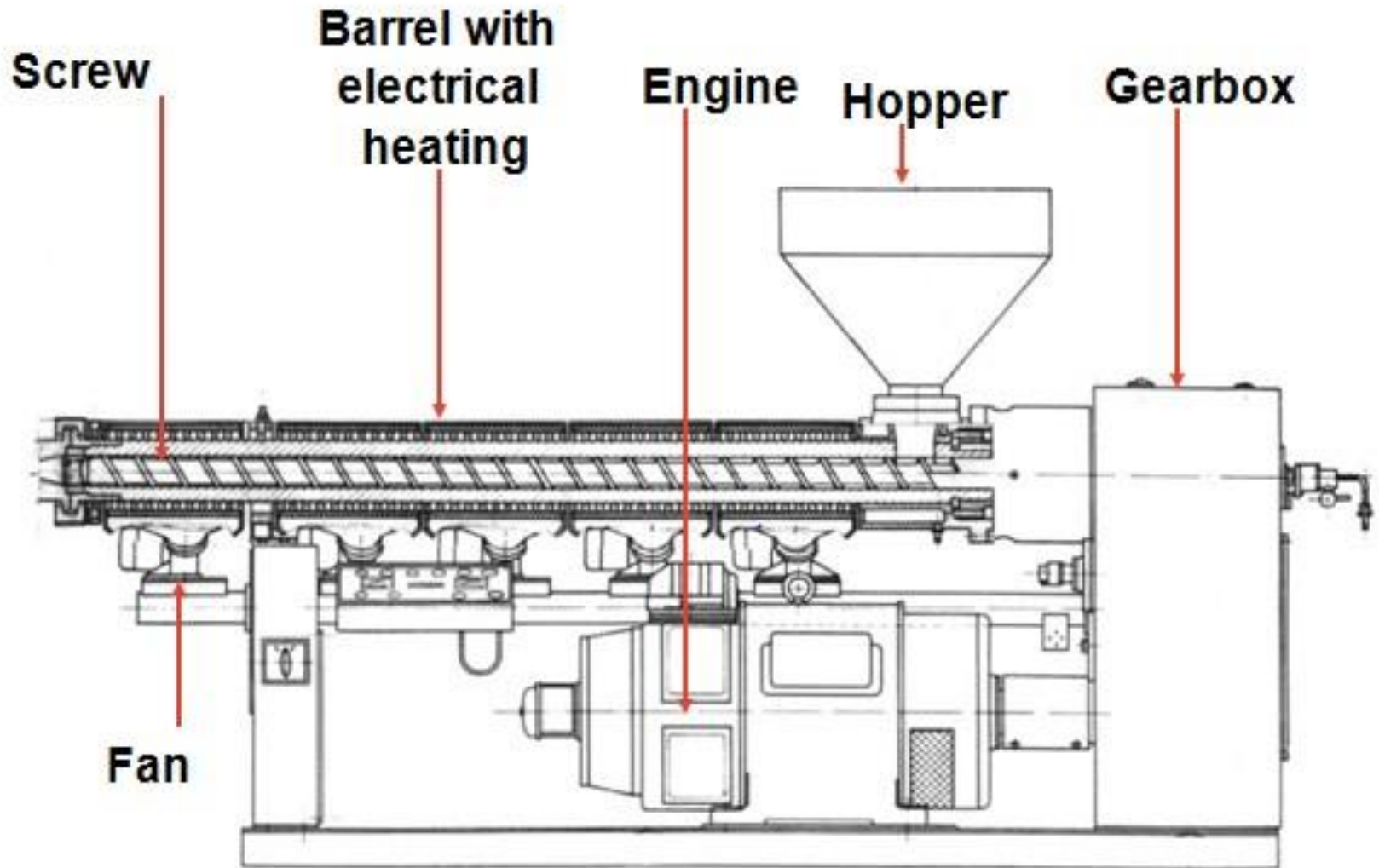

# Screw design

LOW COMPRESSION SCREW <1.5 COMPRESSION RATIO

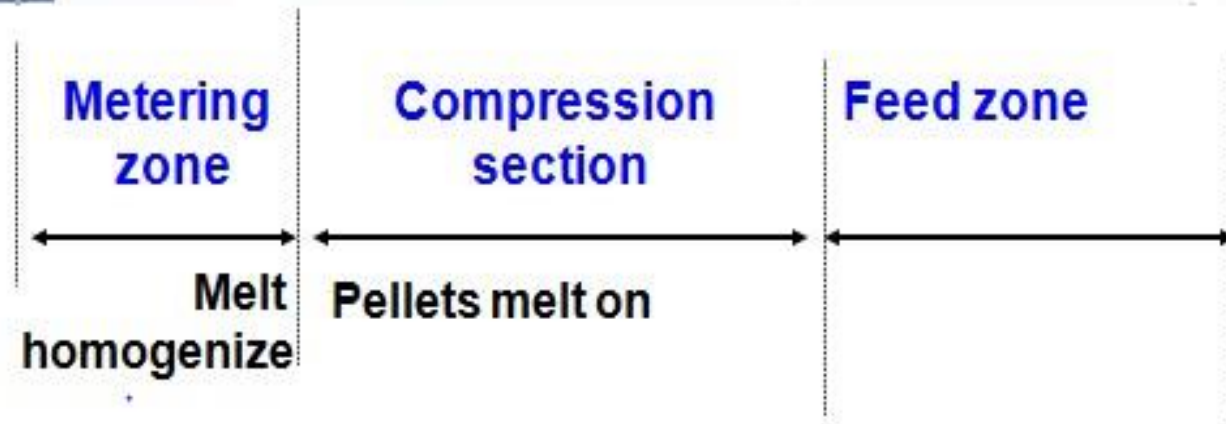

# Screw design: mixing parts

Improvement of melt homogeneity for higher output

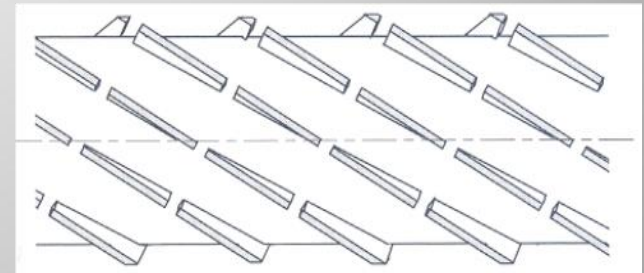

Melt dispersion

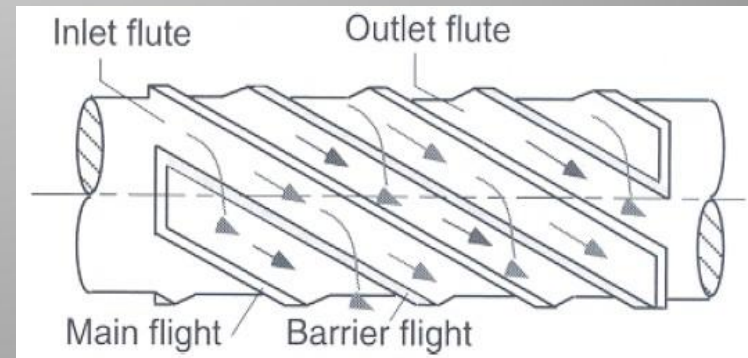

# HFFR : Processing parameters

## Melt - temperature of Material

COPO / ATH	150 °C	130 °C	100 °C
COPO / Si / Chalk	190 °C	170 °C	120 °C

Pellets

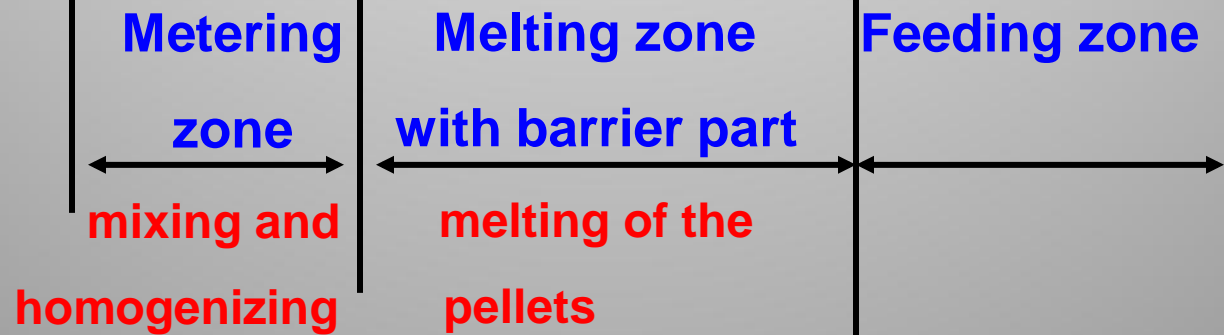

# HFFR : Screw tip / screening

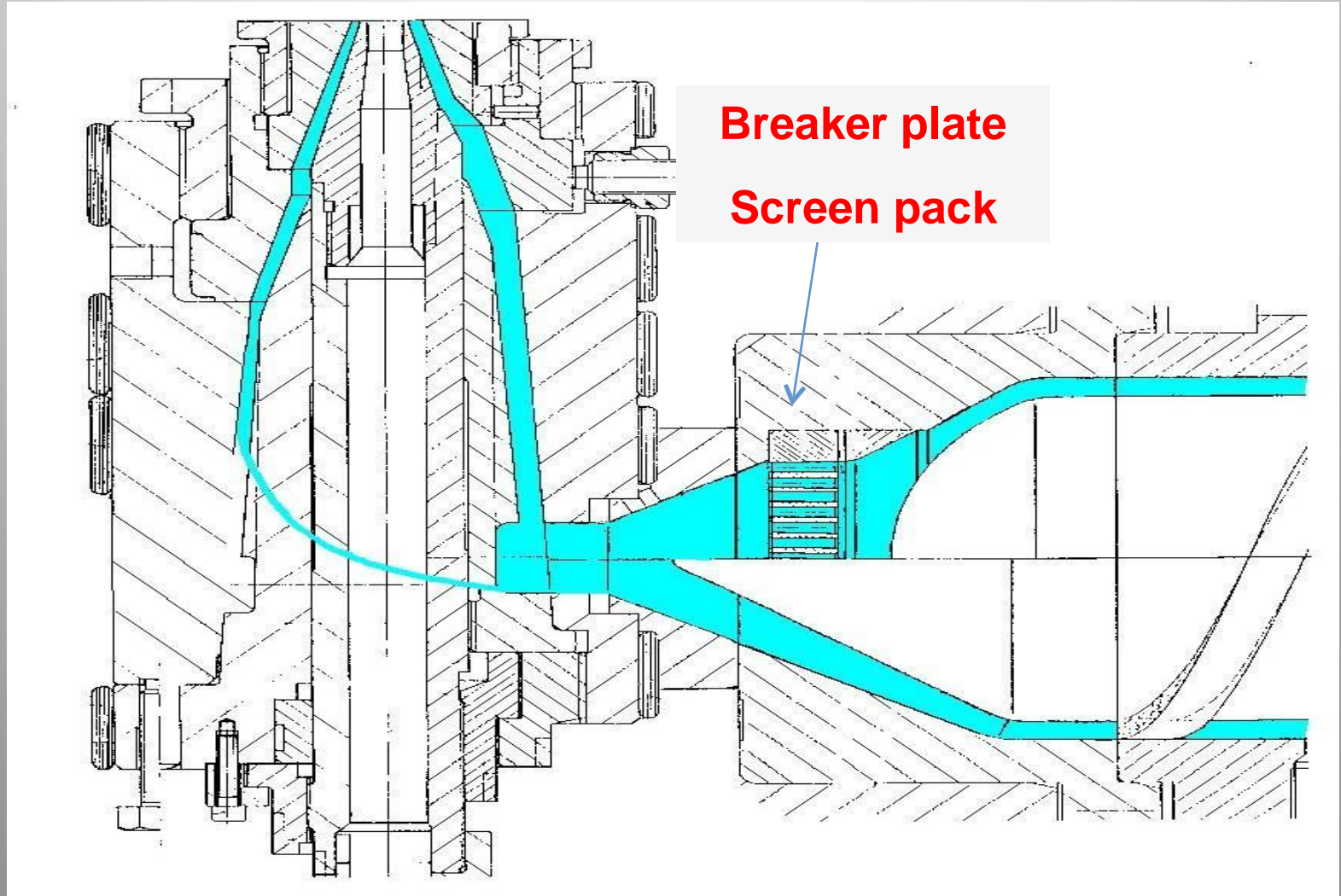

# HFFR: Tool design

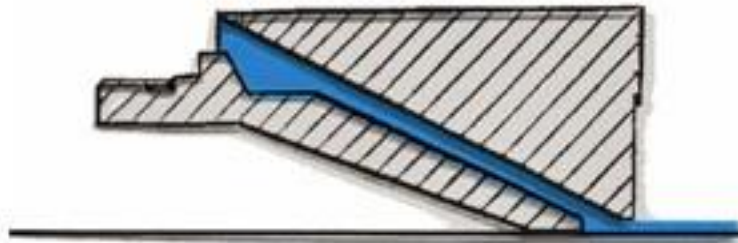

**Pressure design**

**Tube design**

# HFFR: Tube tools



**Tube tool**



**Head vacuum**

**Define, short  
Tube length**



# Summery : Extrusion parameters

## Polymer mix / Silicone / Chalk filler system:

- PE / PVC extruder with standard equipment
- Temperature profile 160 – 180 °C

## Polymer mix / ATH filler system:

- Low compression screw and controlled melt temperature
- Screw tempering 70 – 80 °C
- Deep flow channel inside crosshead to reduce back pressure
- Temperature profile 130 – 160 °C
- Pressure / semi tubing to avoid shrinkage problems
- Quick water cooling to avoid bubbles

# HFFR: Stress cracking test

## Cracktest for HFFR-Material

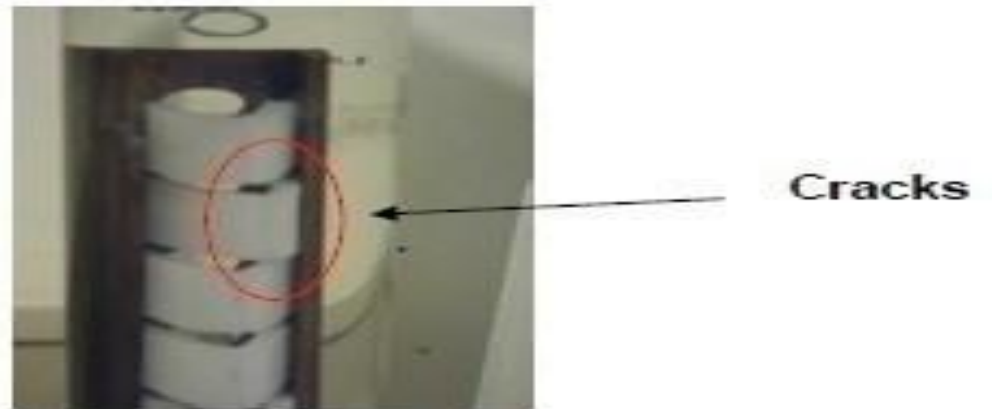

The sample preparation for the Cracktest is similar to VDE 0472 Teil 810 Verfahren 1 or IEC 811-4-1 (1985) environmental stress cracking.

At first we mix the HFFR-Granulate on a roll at 140°C. The homogenous material as it comes from the rolls has a wall thickness about 4-5 mm. From this we press plates 200x200x3,3 mm at 150°C.

Now we cut the plate in test pieces 38x13 mm.

Each sample will be cut by a blade (IEC 811-4-1 page 11). After this we take 5 samples in a special holder (figure 5).

We put the holder with the samples in an oven by 70°C or 80°C and look after different times for cracks.

# Cable test: **New European Standard**

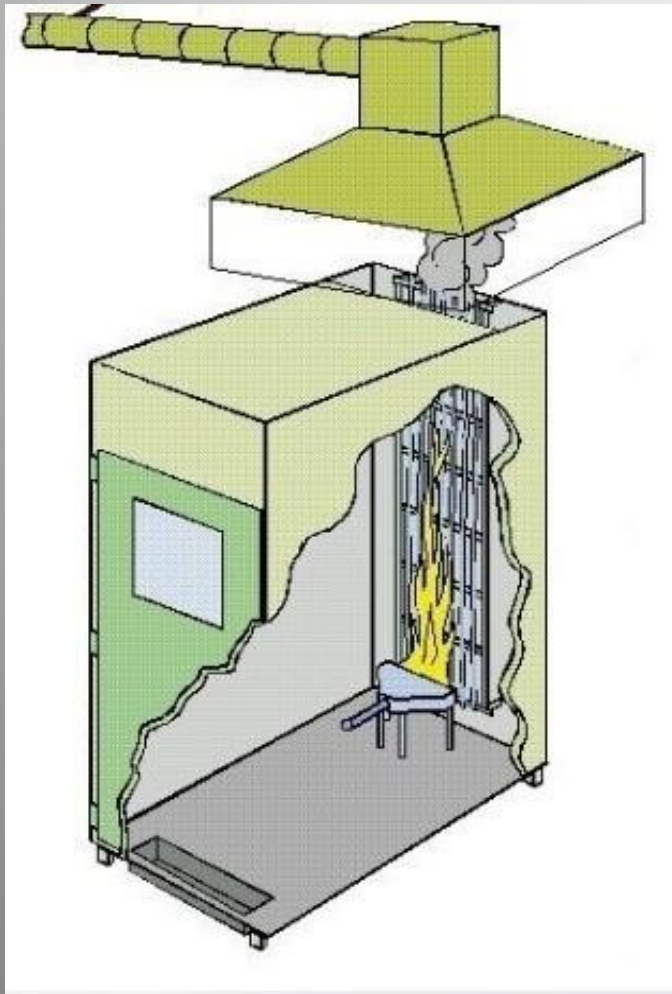

## Gas Analysis Instrumentation

These are housed in a 19" instrument rack containing: -

- Oxygen Analyser (paramagnetic) supplied with temperature and pressure compensation for primary heat release measurement.
- Carbon Dioxide Analyser (infrared) for use in heat release measurement.
- Dual stage soot filter, refrigerant cold trap, drying column, pump and waste regulators for conditioning the sample gases prior to analysis.
- Controls for the smoke measurement system (if purchased).



# HFFR: Crosslinking

- Improved temperature resistance
- Improved drip resistance when burning
- Improve creep resistance (*deformation under load*)
- Improved chemical resistance (*stress cracking*)
- Improved impact resistance
- Increase abrasion resistance

Eg T3 cables for automotive applications in severe chemical environment (oil, lubricants, battery acids and heat)